

## OVERVIEW

Vicor offers RoHS compliant modules. These modules have a “VE” prefix. The information presented herein applies to both versions, and “VI” will be the default designation.

The heart of Vicor’s VI-/MI-200 and VI-/MI-J00 module technology, zero-current-switching, allows Vicor converters to operate at frequencies in excess of 1 MHz, with high efficiency and power density. Depending on input voltage and load, the converters operate at frequencies ranging from the low hundreds of kilohertz (light load, high line) to approximately one megahertz (full load, low line). Another aspect of the Vicor topology is that two or more power trains driven at the same frequency will inherently load-share if their outputs are tied together. Load sharing is dynamic and is within 5%. The VI-200 and MI-200 product line offer both Driver and Booster modules:

- Drivers and Boosters must have identical power trains.
- Drivers close the voltage loop internally, Boosters do not.
- Boosters may be slaved to a Driver, allowing configurations of multi-kilowatt arrays, which exhibit dynamic current sharing between modules.
- Only a single control connection is needed between modules with all module’s power inputs and outputs, connected together — no trimming, adjustments, or external components are required to achieve load sharing.

## LOSSLESS ENERGY TRANSFER

Referring to Figure and Table 1–1 below, turn-on of the MOSFET switch transfers a quantized energy packet from the input source to an LC “tank” circuit, composed of inherent transformer leakage inductance of T1 and a capacitive element, C, in the secondary. Simultaneously, an approximately half-sinusoidal current flows through the switch, resulting in switch turn-on at zero current and turn-off when current returns to zero. Resonance, or bidirectional energy flow, cannot occur because D1 will only permit unidirectional energy transfer. A low-pass filter (Lo, Co) following the capacitor produces a low ripple DC output. The result is a virtually lossless energy transfer from input to output with greatly reduced levels of conducted and radiated noise.

$I_p$ : Primary current
$V_p$ : Primary voltage
$V_s$ : Secondary voltage
OVP: Overvoltage protection (output)
OTS: Over temperature shutdown
OC1, OC2: Opto-coupler
E/A: Error amplifier
REF: Bandgap reference
C/L: Current limit amplifier

Table 1–1

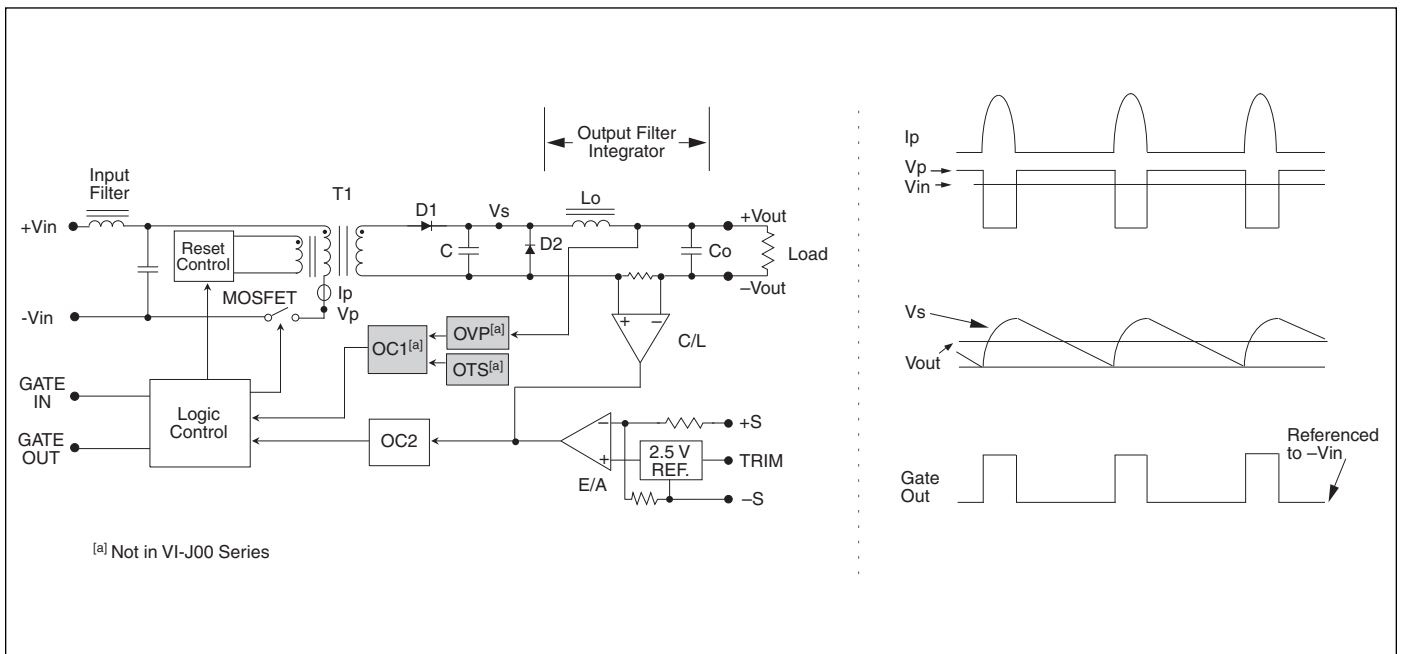

Figure 1–1 — VI-/MI-200 and VI-/MI-J00 series zero-current-switching block diagram