

OVERVIEW

The BatMod is a programmable current source module that is intended for battery charging or similar current source applications. It can be controlled externally to meet a wide range of charging parameters: voltage, current, charge rate and charge time.

The BatMod is comparable to the VI-200 voltage source module but with a variable current limit. It has three output pins that differ from the VI-200 converters: Current Control (I_{TRIM}), Voltage Adjust (V_{TRIM}) and Current Monitor (I_{MON}). All of these pins are referenced to the -OUT pin.

Although the BatMod is primarily intended for battery charge applications it can be used as a programmable current source for resistive loads or CW laser diodes. The BatMod will not function properly at zero output voltage and current simultaneously. It follows therefore that the current can not be adjusted to zero with a resistive load. Refer to Safe Operating Area Curves on the [BatMod data sheet](#), which can be found at vicorpower.com.

PINOUT DESCRIPTION

Current Control (I_{TRIM}). An input which can receive an analog control voltage from 1 – 5 V for adjustment of the sourced current from zero to maximum rating of the BatMod.

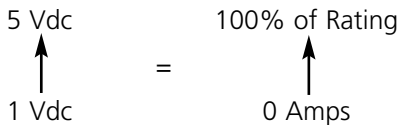

Voltage Adjust (V_{TRIM}). An input for controlling or setting the output setpoint, this is similar to the trim function on the VI-200. (Section 5) A maximum voltage can be set by a fixed resistor or adjusted with an external voltage source. A source voltage referenced to -OUT adjusted from 1.25 – 2.5 V will program a 50 – 100% of rated voltage setting.

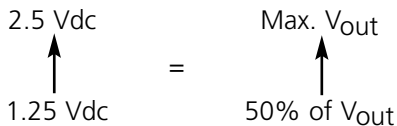

It is important to note the nominal output voltage for each BatMod type untrimmed.

- 12 V_{out} Part # = 15 V actual
- 24 V_{out} Part # = 30 V actual
- 48 V_{out} Part # = 60 V actual

Current Monitor (I_{MON}). An output that indicates the amount of current being sourced. It is a linear voltage / current relationship where one volt corresponds to 0% of sourced current and 5 V corresponds to 100% of sourced current.

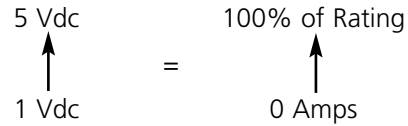

For DC input / current source applications (Figure 11-1), the BatMod has a similar wide range input rating as the VI-200 Family of voltage converters for 48 and 300 V inputs. BatMods can be used for higher current source applications with a Driver / Booster approach. (Figure 11-2)

NOTE: Inductance to the load should be limited to 20 μH to avoid possible loop instabilities.

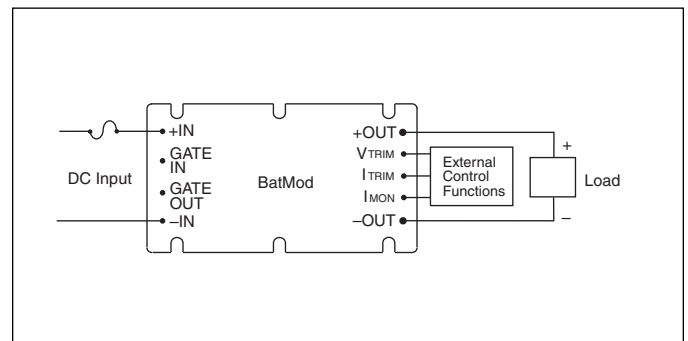

Figure 11-1 — DC input single module

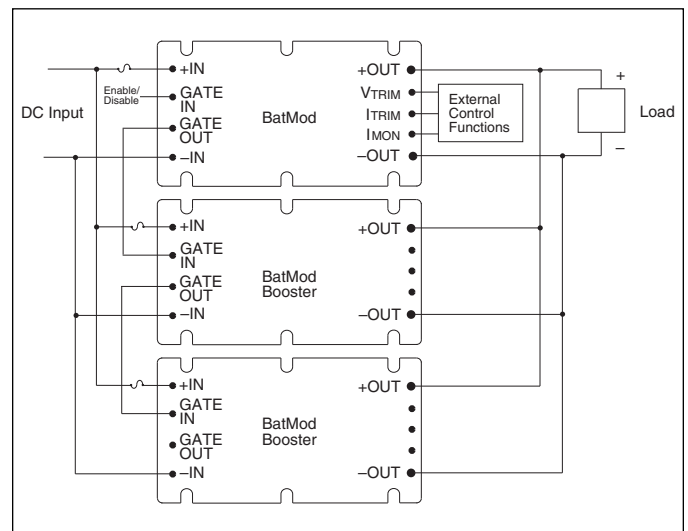

Figure 11-2 — DC input high power array

DESIGNING A BATTERY CHARGER

Vicor's BatMod (current source module) enables designers to easily build a compact, lightweight battery charging system with commonly available parts. The BatMod provides programmable output current and output voltage capability. Since the BatMod allows the output voltage and the charge current to be set independently, the system design is greatly simplified.

Basic Battery Charger. Figure 11–3, shows a basic charging circuit with a BatMod for the following system requirements:

Battery voltage: 12 V

Float voltage: 13.8 V

Charge current: Adjustable 0 – 14.5 A

Setting the Float Voltage. Since the open circuit output of a 12 V BatMod (VI-2x1-CU-BM) is 15 V, a trim resistor (R3) is necessary to set the float voltage of 13.8 V.

Steps to determine the value of R3:

Solve for V_{TRIM} :

$$\left(\frac{V_{FLOAT}}{V_{NOM}} \right) V_{REF} = V_{TRIM}$$

$$\left(\frac{13.8 \text{ V}}{15 \text{ V}} \right) 2.5 \text{ V} = 2.3 \text{ V}$$

Solve for V_{R5} :

$$V_{REF} - V_{TRIM} = V_{R5}$$

$$2.5 \text{ V} - 2.3 \text{ V} = 0.2 \text{ V}$$

Solve for I_{R5} :

$$I_{R5} = \frac{V_{R5}}{R5} = \frac{0.2 \text{ V}}{10 \text{ k}\Omega} = 20 \text{ }\mu\text{A}$$

Solve for R3:

$$\frac{V_{TRIM}}{I_{R5}} = R3$$

$$\frac{2.3 \text{ V}}{20 \text{ }\mu\text{A}} = 115 \text{ k}\Omega$$

A 13.8 V output requires a 115 k Ω resistor.

Setting the Charge Current. The charge current can be programmed from 0 to maximum (14.5 A) by applying 1 – 5 V to the I_{TRIM} pin. To determine the voltage required to produce a particular charge current, 10 A for example, use the following formula:

$$4 \left(\frac{\text{Desired Charge Current}}{\text{Maximum Output Current}} \right) + 1 = I_{TRIM} \text{ voltage}$$

$$4 \left(\frac{10 \text{ A}}{14.5 \text{ A}} \right) + 1 = 3.76 \text{ V}$$

To set the input voltage at I_{TRIM} to 3.76 V, adjust the potentiometer (R2) appropriately.

In Figure 11–3 the configuration will charge the battery at a maximum of 10 A with a 13.8 V float voltage. Other charge rates and float voltages may be similarly calculated. If a fixed charge current is desired, the potentiometer can be replaced with two fixed resistors. In applications requiring tight control over the charging current, D1 can be replaced with a precision reference.

Advanced Battery Charger. Many new battery technologies require sophisticated charging and monitoring systems to preserve their high performance and to extend their life. The BatMod serves as an ideal building block for constructing an advanced battery management system, which typically incorporates a microprocessor-based control circuit that is easily adapted for a variety of battery chemistries and monitoring functions. (Figure 11–4)

To maintain the optimum charge on the battery, the control circuit independently adjusts the float voltage and charge current in response to conditions during the charge: the battery's voltage, current, temperature and pressure, and other pertinent parameters. It can also relay battery status information such as capacity, charge and discharge history, and cause of failure.

NOTE: A redundant control or monitoring circuit must be included if failure of the BatMod or its control circuit will result in uncontrolled charging of the battery. Many new battery types are sensitive to these conditions and may result in fire or explosion.

With its wide range of outputs, the BatMod offers designers a simple, cost-effective solution to battery charging for all major battery types.

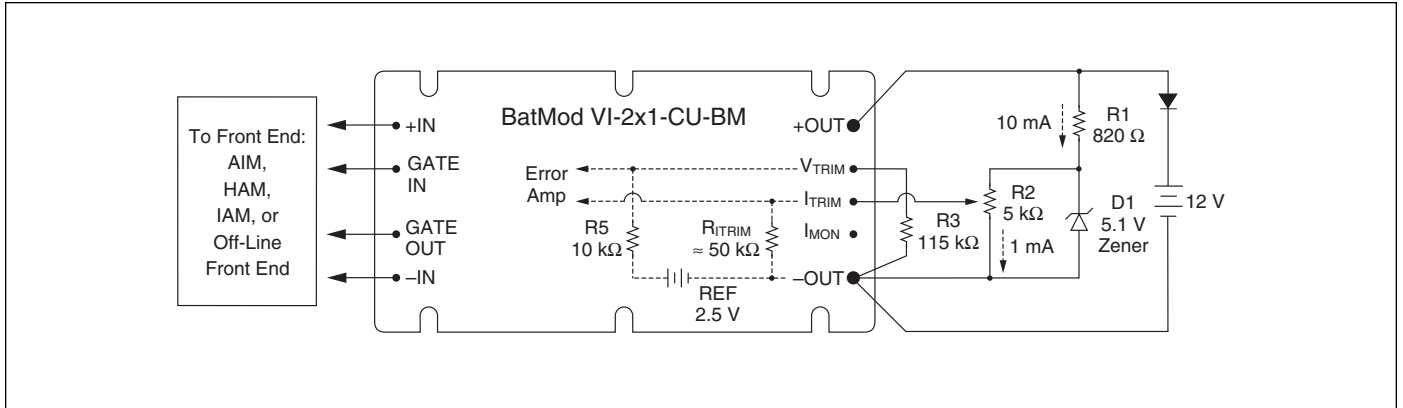

Figure 11-3 — Basic charging circuit using a current source module (BatMod)

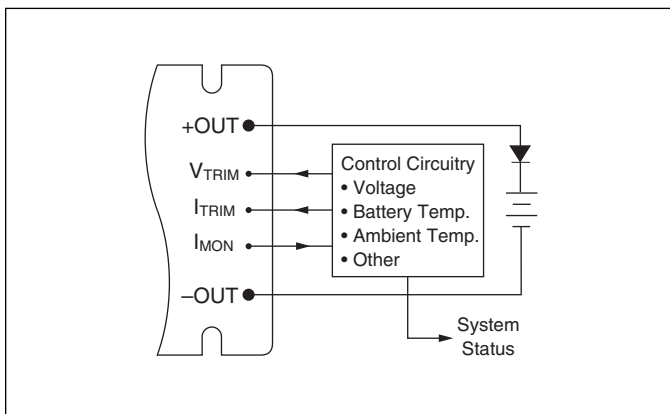

Figure 11-4 — The BatMod in an advanced battery charging system