

**OVERVIEW**

The RAM/MI-RAM is an accessory product for VI-/MI-200, VI-/MI-J00, MegaMod/MI-MegaMod, ComPAC/MI-ComPAC and FlatPAC. It reduces line frequency related ripple and converter switching noise to less than 3 mV p-p (10 mV p-p on the VI-J00).

Features include:

- Reduced differential noise (<3 mV p-p at loads up to 20 A). The input of the RAM must be between 5 – 50 Vdc.
- Active and passive filtering
- Attenuation of low frequency input power source harmonics and high frequency switching components from DC-20 MHz
- Remote sense, trim, overvoltage protection and overcurrent protection features retained

Applications for the RAM include medical diagnostic and automated test equipment, radio receivers, transmitters and communication products, and other products requiring the noise performance of a linear supply. Refer to the [RAM operation](#) in Section 9.

The RAM is a combination active / passive filter. A simplified schematic is shown in Figure 15–2. The output of the switcher feeds directly into a high frequency passive filter which attenuates the switching noise. Low frequency, line related ripple attenuation is via a FET series regulator that maintains a constant average forward voltage drop of about 350 mV. The FET gate is modulated to maintain the AC component of the FET drain-source voltage equal to the ripple component of the incoming DC voltage, effectively cancelling it out.

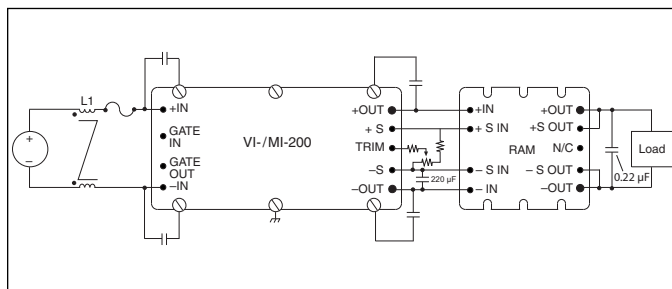

**Figure 15–1** — RAM with optional trimming circuit and recommended common-mode choke

The power supply’s sense leads feed through the RAM for connection at the RAM output, for local sense, or at the load, for remote sense (converter compensation is 0.5 V maximum). The attenuation and insertion loss are constant up to 10 A or 20 A, depending on model. In overload (above 10 A or 20 A), the voltage drop will increase as the current increases. A single RAM can be used on any output from 5 – 50 Vdc and will maintain the original output setpoint of the converter within 0.5% at the SENSE connection. Care should be taken not to connect IN to OUT pins (i.e., through scope probe returns, grounds, etc.) as attenuation will be adversely affected.

Inserting the RAM into the output leads of a Vicor VI-200/VI-J00 converter adds phase shift to the converter’s control loop. This occurs because voltage is sensed at the output of the RAM’s internal filter. The 220µF capacitor between –S IN and –IN (See Figure 15-1) provides additional high frequency bypassing for the sense leads to ensure stability of the converter and RAM. It may be possible to reduce its value or remove it in applications where transient response is important. If it is removed a network analyzer should be used to verify stable operation.

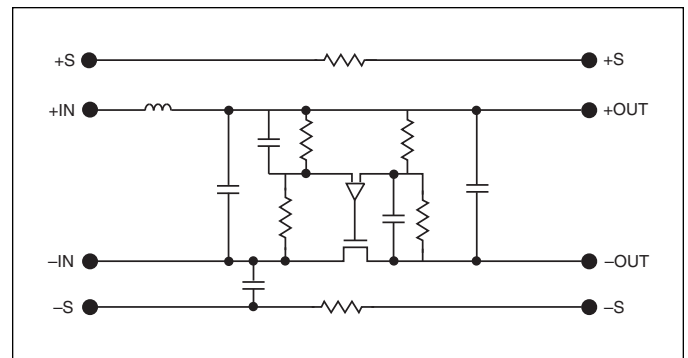

**Figure 15–2** — Basic RAM schematic

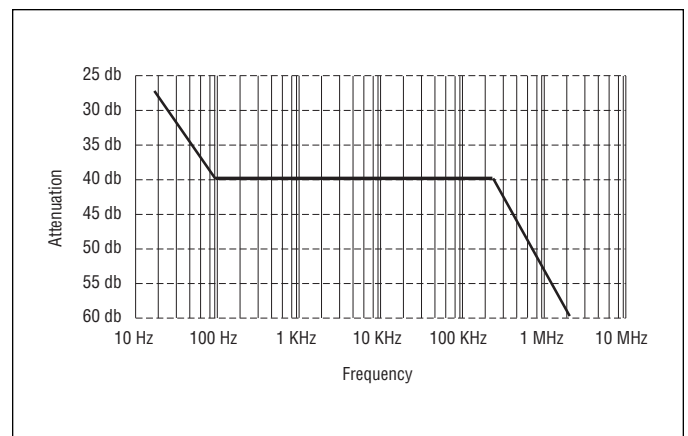

**Figure 15–3** — Attenuation vs. frequency (typical)