

SINGLE PHASE FRONT ENDS

Vicor’s single phase non-isolated AC front ends are available in both PCB and chassis mount versions, and deliver reliable DC bus voltage to VI-x6x converter modules or Mega Modules at power levels up to 250, 500 and 750 W. These front ends are strappable to provide operation from either 115 Vac or 230 Vac single phase lines, and provide conducted EMC filtering to VDE / FCC Level B. They also offer transient surge

protection, active inrush limiting, AC-OK (AC fail indicator), and a BUS-OK status output suitable for controlling Vicor modules via the GATE IN pin.

Vicor’s front ends have been designed to comply with the requirements of major safety agencies when used in conjunction with recommended mains switching and input fusing.

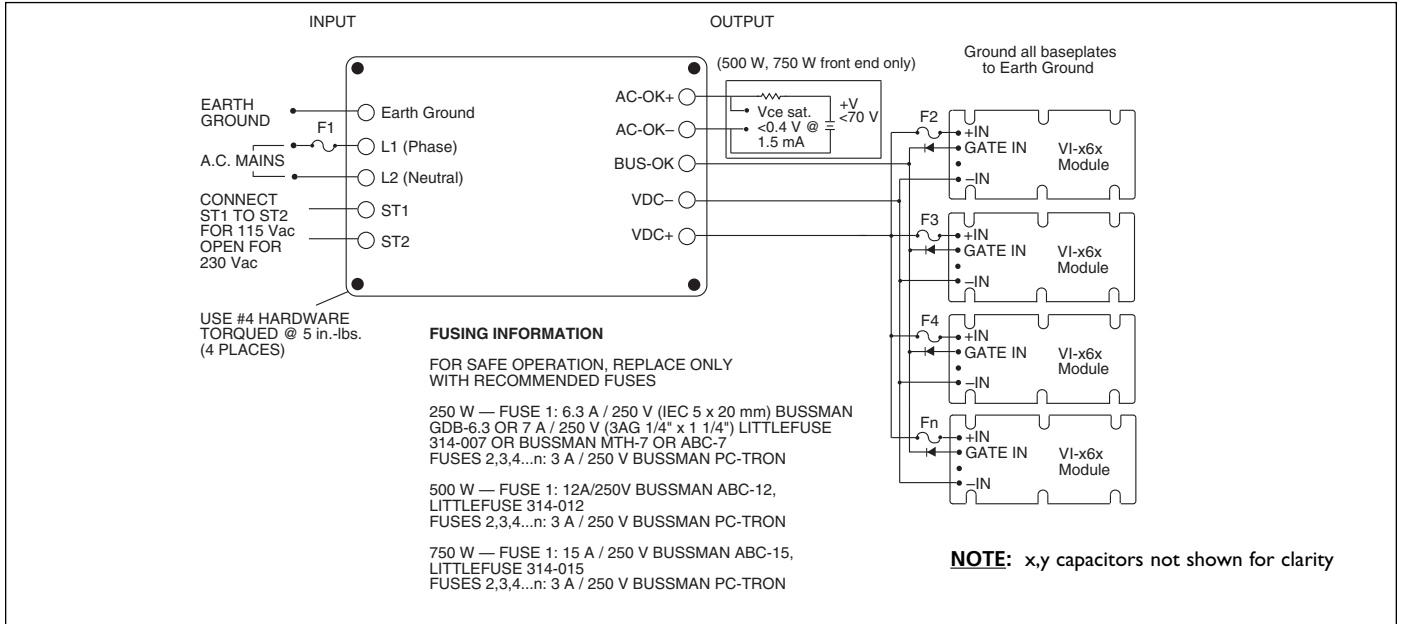

Figure 16-1 — 250 W, 500 W, 750 W front ends

NOTES:

- Ambient temperature must be less than 50°C in free air. Temperature may exceed 50°C with moving air. (refer to derating curves in Figure 16-2)
- Do not obstruct vent holes.
- Observe module installation requirements (refer to [Module Do & Don'ts](#), Section 3).
- Minimize length of all unshielded line cord.
- Minimum conductor size for supply is 16 AWG (250 W), 14 AWG (500 W) and 12 AWG (750 W) including the 115/230 strap.
- If the DC output bus is shorted before application of AC power, the fuse may not blow, and the unit will not turn on.
- If wire distance from front end to modules is greater than 3 feet, (0.91 m) install a TRANSZORB (Part #1.5KE400A) across the input of each module.
- If unit is strapped for 115 V operation and 230 V is applied, the input fuse will clear. Replace fuse, strap correctly and reapply power.
- To control EMC most effectively, the return path to ground from either the front end or modules should be made via a good RF ground (i.e., a braided wire) if possible.
- The BUS-OK, Vdc- and Vdc+ lines should be run in close proximity to one another or as a twisted group between the front end and modules.
- Bypass the baseplates of the modules to -IN and -OUT (refer to [EMC Considerations](#), Section 9).

THERMAL CONSIDERATIONS

Free Convection Derating.

- 250 W: Derate output power linearly at 7.2 W/°C over 50°C.
- 500 W: Derate output power linearly at 14.3 W/°C over 50°C.
- 750 W: Derate output power linearly at 18.8 W/°C over 45°C.

Forced Convection. The curves to the right represent worst case data for chassis mounted (enclosed) front ends; i.e., low line, full load. System conditions such as higher line voltage, lighter load or PC mount versions of the front ends will increase reliability if the following data is used as the nominal design criteria.

The sigmoid shape of the curves at low airflow is due to the chassis mount cover restricting the airflow to the inboard components. When an airflow of approximately 200 LFM is achieved, the velocity of air rushing over the cover causes air to be pulled in through the side perforations, resulting in a rapid improvement in the cooling of internal components.

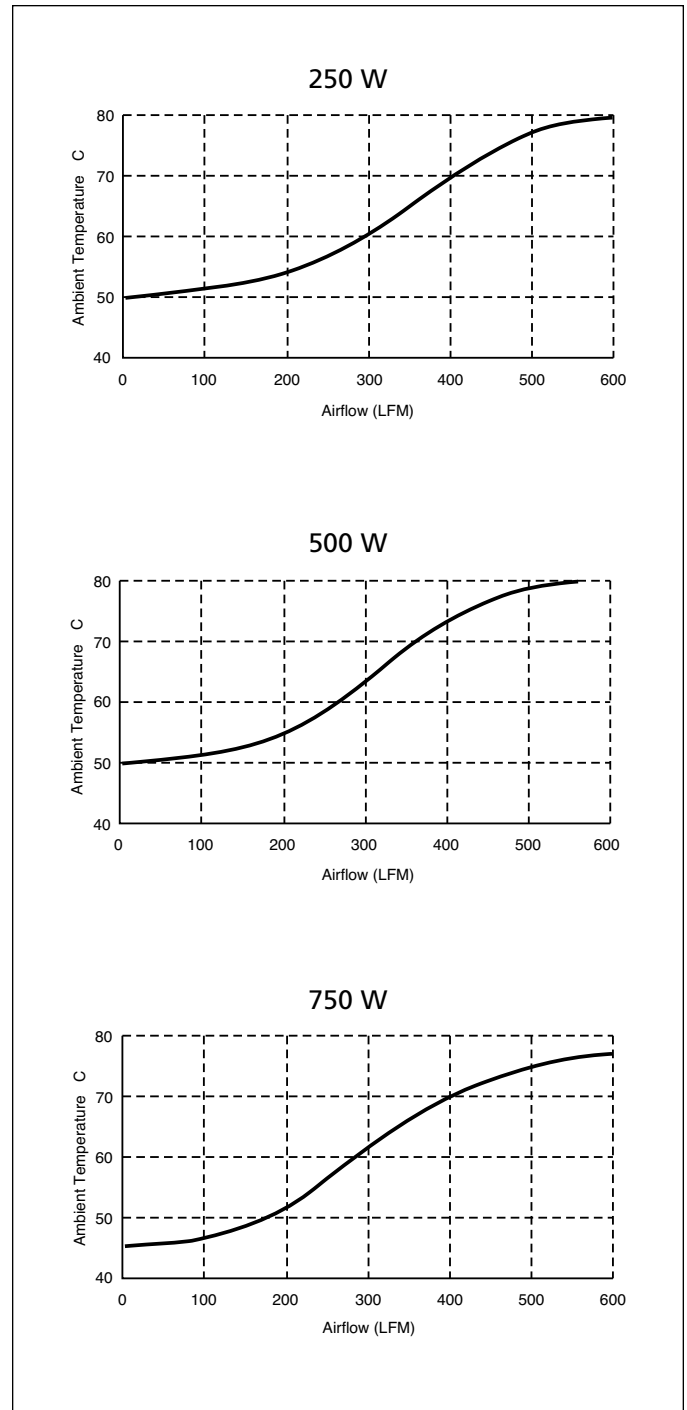

Figure 16-2 — Maximum ambient temperature vs. airflow (LFM) over cover (full load, 90 Vac Input, chassis mount)

3-PHASE FRONT ENDS

Vicor’s 3-phase front-ends are available as chassis mount products that deliver reliable DC bus voltage to VI-x6x Family (nominal 300 Vdc input) converters up to 1.5 kW, 3 kW and 5 kW.

Front ends operate from 3-phase (4-wire delta or 4 or 5-wire wye) AC mains input and provide conducted EMC filtering to VDE/FCC Class A, transient surge protection, inrush current limiting and ENABLE output suitable for controlling an array of Vicor converters via the GATE IN

pin. Isolated AC-OK and BUS-OK outputs are also provided for advance warning of DC bus dropout due to AC line failure and indication of internal DC bus integrity in the user system, respectively.

These front ends have been designed to comply with the requirements of major safety agencies when used in conjunction with the recommended mains switching and input fusing.

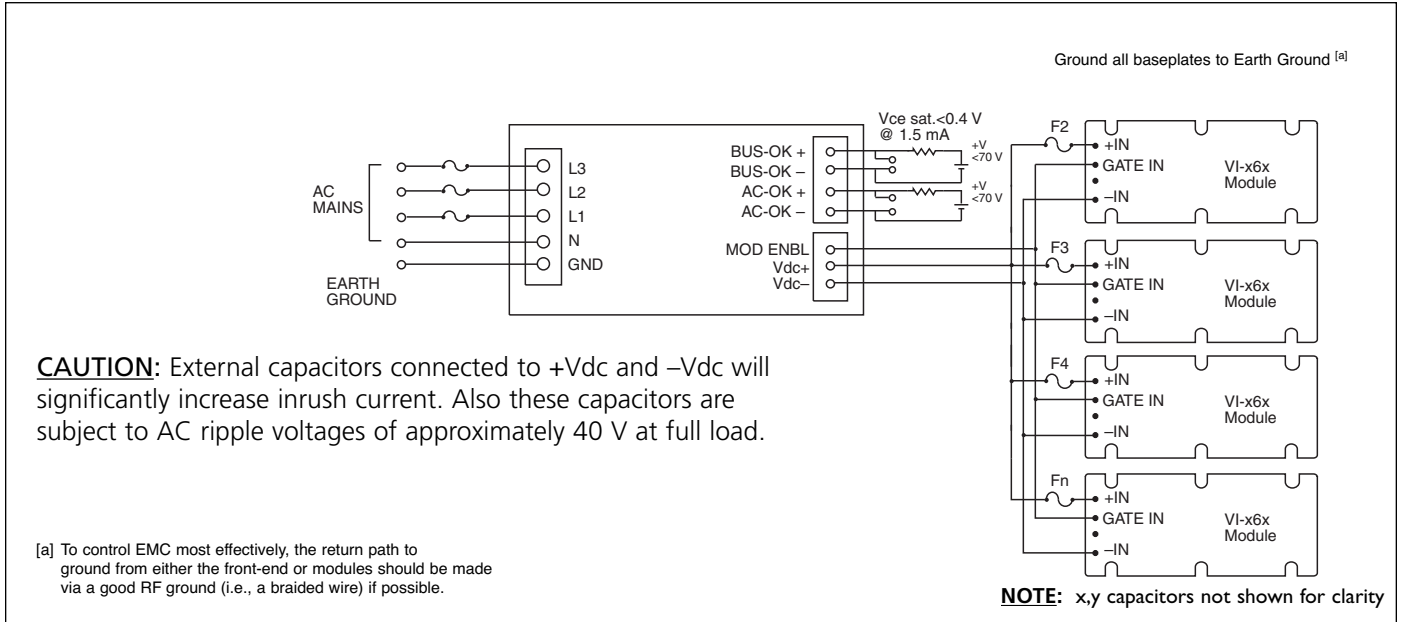

Figure 16-3 — 1.5, 3.0 kW Front-end

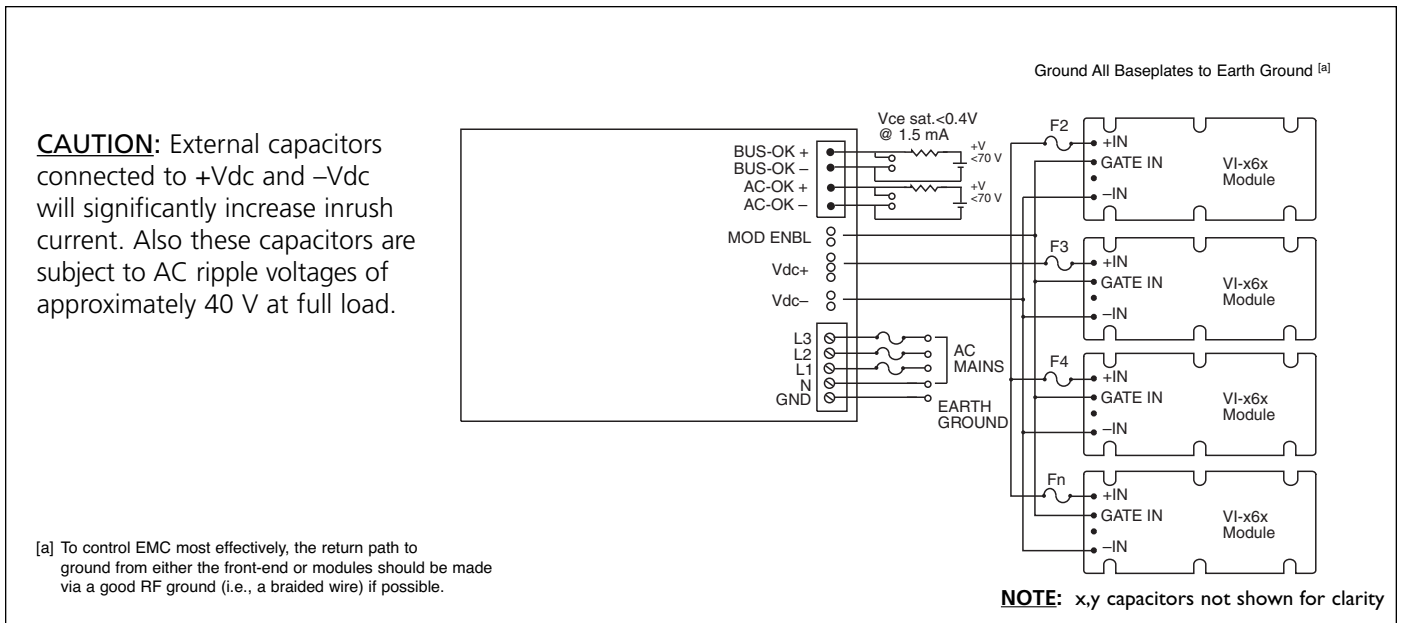

Figure 16-4 — 5.0 kW Front-end

FUSING INFORMATION

- 1.5 kW front end: 7 A / 250 V normal blow in all three phases of the AC line (Bussman ABC-7 or Littlefuse 314-007).
- 3 kW front end: 12 A / 250 V normal blow in all three phases of the AC line (Bussman ABC-12 or Littlefuse 314-012).
- 5 kW front end: 20 A / 250 V normal blow in all three phases of the AC line (Bussman ABC-20).

ENVIRONMENTAL DATA

- Operating temperature (no load to full load):
–20°C to +50°C, free convection
- Non operating temperature: –40°C to +80°C
- Operating / non-operating humidity:
95% relative, non-condensing

ELECTRICAL DATA — AC LINE INPUT VOLTAGE CONNECTIONS (PHASE TO PHASE)

- 3-phase delta (4 wire): 208 Vac (nominal) +20% / –10%. Connect the three phases (L1, L2, L3) and GND (earth) to the five terminal barrier block marked as such.
- 3-phase wye distribution (5-wire): 208 Vac (nominal) +20% / –10%. Connect the three phases (L1, L2, L3), N (neutral), and GND (earth) to the five terminal barrier block marked as such.
- Line frequency: 47 – 440 Hz

DC OUTPUT CONNECTIONS AND MODULE ENABLE

A three terminal barrier block labeled Vdc–, Vdc+ and MOD EN provides both the DC input enable and enable control line for Vicor converters.

- Vdc–: Negative DC input terminal to all Vicor converters.
- Vdc+: Positive DC input terminal to all Vicor converters.
- MOD EN: Connect to the GATE IN terminal of all Driver modules. This connection must be made to guarantee proper enabling of the converter array on power-up and proper shut down of the converter array on power loss, loss of phase or output fault.

CAUTIONS

- This product is designed to operate with Vicor VI-x6x Family (300 Vdc input) converters, Mega Modules and the 300 Vin Maxi, Mini and Micro converters.
- This product is not intended for use with European 380 – 415 Vac three phase distribution.
- This product is an offline AC-DC power supply. It is not isolated from the AC mains.
- Proper grounding is mandatory for safe operation.