

OVERVIEW

Specifications such as efficiency, ripple and input voltage range are a function of output voltage settings. As the output voltage is trimmed down, efficiency goes down; ripple as a percent of Vout goes up and the input voltage range widens since input voltage dropout (loss of regulation) moves down. As the units are trimmed up, the reverse of the above effects occurs.

All converters have a fixed current limit. The overvoltage protection setpoint is also fixed; trimming the output voltage does not alter its setting. As the output voltage is trimmed down, the current limit setpoint remains constant. Therefore, in terms of output power, if the unit is trimmed down, available output power drops accordingly.

The output voltage of most Vicor converters can be trimmed +10%, -50%. Certain modules have restricted trim ranges. Consult the latest datasheet for details.

Do not attempt to trim the module output voltage more than +10%, as overvoltage shut down may occur. Do not exceed maximum rated output power when the module is trimmed up.

CAUTION: When trimming up VI-/MI-J00 converter modules, additional care should be taken as an improper component selection could result in module failure. Improper connection of the sense leads on VI-/MI-J00 converter modules can also result in an excessive overvoltage condition and module failure.

The following procedures describe methods for output voltage adjustment (-10 to +10% of nominal) of the VI-/MI-200, VI-/MI-J00, ComPAC/MI-ComPAC, FlatPAC and MegaMod/MI-MegaMod Families.

Modules with nominal 3.3 V outputs and above have the 2.5 V precision reference and 10 k internal resistor. For trim resistor calculations on modules with 2.0 V outputs use 0.97 V in place of the 2.5 V reference and substitute 3.88 kΩ for the internal 10 kΩ resistor.

Resistors are 0.25 W. When trimming down any module, always maintain a minimum preload of at least 1% of rated output power and in some cases up to 10% may be required. For more specific information on trimming down a specific module, please consult Vicor's Applications Engineering Department at (800) 927-9474.

RESISTIVE ADJUSTMENT PROCEDURE

To achieve a variable trim range, an external resistor network must be added. (Figure 5-1)

Example 1. For trimming -10% to +10% with a standard off-the-shelf 10 kΩ potentiometer (R7), values for resistors R6 and R8 need to be calculated.

Resistor R6 limits the trim down range. For a given percentage, its value is independent of output voltage. Refer to [Table 5-1](#), for limiting resistor values.

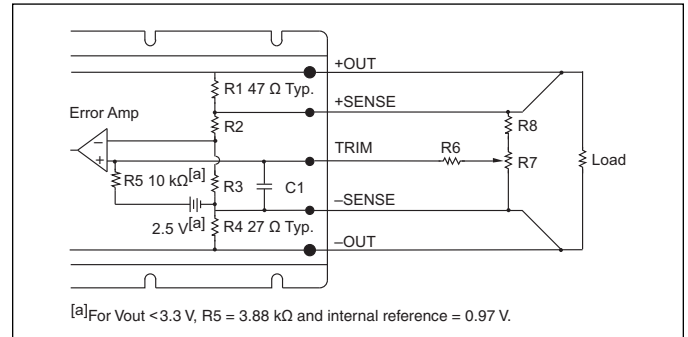

Figure 5-1 — External resistive network for variable trimming

TRIMMING DOWN -10%

A 10% drop of the 2.5 V reference at the TRIM pin is needed to effect a 10% drop in the output voltage. (Figure 5-2)

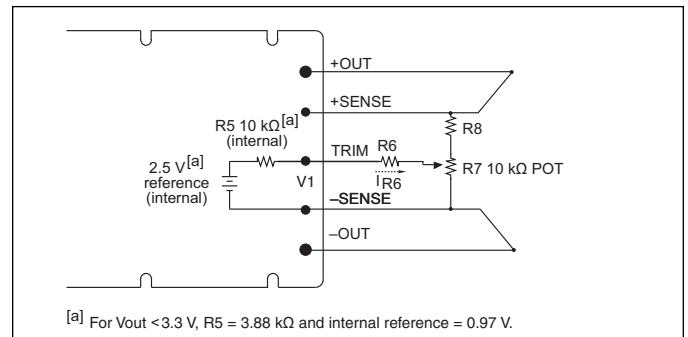

Figure 5-2 — Circuit diagram "Trim Down"

$$V_1 = 2.5 \text{ V} - 10\% = 2.25 \text{ V}$$

Therefore:

$$I_{R5} = \frac{(2.5 \text{ V} - 2.25 \text{ V})}{10 \text{ k}\Omega} = 25 \mu\text{A}$$

Since $I_{R5} = I_{R6} = 25 \mu\text{A}$:

$$R_6 = \frac{2.25 \text{ V}}{25 \mu\text{A}} = 90 \text{ k}\Omega$$

This value will limit the trim down range to -10% of nominal output voltage.

TRIMMING UP +10%

To trim 10% above the nominal output voltage, the following calculations are needed to determine the value of R8. This calculation is dependent on the output voltage of the module. A 12 V output will be used as an example. (Figure 5–3)

It is necessary for the voltage at the TRIM pin to be 10% greater than the 2.5 V reference. This offset will cause the error amplifier to adjust the output voltage up 10% to 13.2 V.

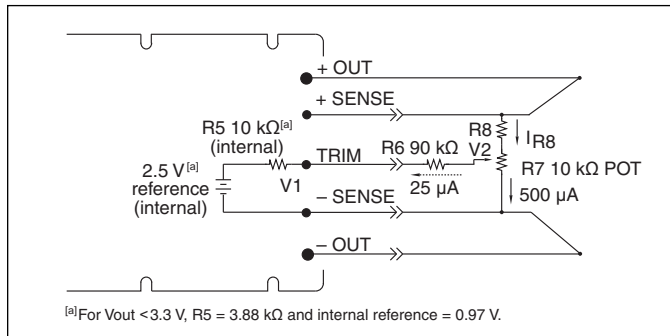

Figure 5-3 — Circuit diagram “Trim Up”

$$V_1 = 2.5 \text{ V} + 10\% = 2.75 \text{ V}$$

$$I_{R5} = \frac{(2.75 \text{ V} - 2.5 \text{ V})}{10 \text{ k}\Omega} = 25 \mu\text{A}$$

Since $I_{R5} = I_{R6}$, the voltage drop across R6 = (90 kΩ) (25 μA) = 2.25 V.

Therefore, $V_2 = 2.75 \text{ V} + 2.25 \text{ V} = 5 \text{ V}$. The current through R7 (10 kΩ pot) is:

$$I_{R7} = \frac{V_2}{R7} = \frac{5}{10 \text{ k}} = 500 \mu\text{A}$$

Using Kirchoff's current law:

$$I_{R8} = I_{R7} + I_{R6} = 525 \mu\text{A}$$

Thus, knowing the current and voltage, R8 can be determined:

$$V_{R8} = (V_{\text{out}} + 10\%) - V_2 = 13.2 \text{ V} - 5 \text{ V} = 8.2 \text{ V}$$

$$R8 = \frac{(8.2 \text{ V})}{525 \mu\text{A}} = 15.6 \text{ k}\Omega$$

This resistor configuration allows a 12 V output module to be trimmed up to 13.2 V and down to 10.8 V. Follow this procedure to determine resistor values for other output voltages.

FIXED TRIM

Converters can be trimmed up or down with the addition of one external resistor, either Ru for programming up or Rd for programming down. (Figure 5–4)

Example 2. Fixed Trim Up (12 V to 12.6 V).

To determine Ru, the following calculation must be made:

$$2.5 \text{ V} + 5\% = 2.625 \text{ V}$$

$$V_{R5} = V_{\text{TRIM}} - V_{\text{ref}}$$

$$V_{R5} = 2.625 - 2.5 = 0.125 \text{ V}$$

Knowing this voltage, the current through R5 can be found:

$$I_{R5} = \frac{V_{R5}}{R5} = \frac{0.125}{10 \text{ k}\Omega} = 12.5 \mu\text{A}$$

$$V_{Ru} = 12.6 \text{ V} - 2.625 \text{ V} = 9.975 \text{ V}$$

$$R_u = \frac{9.975}{12.5 \mu\text{A}} = 798 \text{ k}\Omega$$

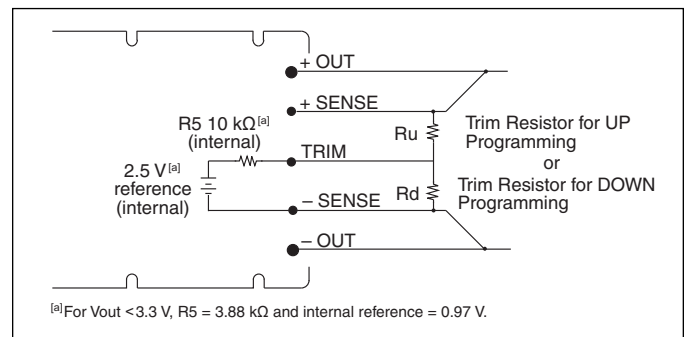

Figure 5-4 — Fixed trimming

Connect Ru from the TRIM pin to the +SENSE. Be sure to connect the resistor to the +SENSE, not the +OUT, or drops in the positive output lead as a function of load will cause apparent load regulation problems.

Example 3. –25% Fixed Trim Down (24 V to 18 V).

The trim down methodology is identical to that used in Example 2, except that it is utilized to trim the output of a 24 V module down 25% to 18 V. The voltage on the TRIM pin must be reduced 25% from its nominal setting of 2.5 V. This is accomplished by adding a resistor from the TRIM pin to –SENSE.

$$2.5 \text{ V} - 25\% = 1.875 \text{ V}$$

$$V_{R5} = V_{\text{bandgap}} - V_{\text{TRIM}}$$

$$= 2.5 \text{ V} - 1.875 \text{ V} = 0.625 \text{ V}$$

Knowing this voltage, the current through R5 can be found:

$$I_{R5} = \frac{V_{R5}}{R5} = \frac{0.625}{10 \text{ k}\Omega} = 62.5 \mu\text{A}$$

The voltage across the resistor, R_d, and the current flowing through it are known:

$$R_d = \frac{(2.5 \text{ V} - 0.625 \text{ V})}{62.5 \mu\text{A}} = 30 \text{ k}\Omega$$

Connect R_d (Figure 5–4) from the TRIM pin to the –SENSE of the module. Be sure to connect the resistor to the –SENSE, not the –OUT, or drops in the negative output lead as a function of load will cause apparent load regulation problems.

DYNAMIC ADJUSTMENT PROCEDURE

Output voltage can also be dynamically programmed by driving the TRIM pin from a voltage or current source; programmable power supplies and power amplifier applications can be addressed in this way. For dynamic programming, drive the TRIM pin from a source referenced to the negative sense lead, and keep the drive voltage in the range of 1.25 – 2.75 V. Applying 1.25 – 2.5 V on the TRIM pin corresponds to 50 – 100% of nominal output voltage. The actual voltage range is further restricted by the allowable trim range of the converter. Voltages in excess of 2.75 V (+10% over nominal) may cause overvoltage protection to be activated. For applications where the module will be programmed on a continuous basis the slew rate should be limited to 30 Hz.

Values for Trim Down by Percentage	
Percent	Resistance
-5 %	190 kΩ
-10 %	90 kΩ
-15 %	56.7 kΩ
-20 %	40 kΩ
-25 %	30 kΩ
-30 %	23.3 kΩ
-35 %	18.6 kΩ
-40 %	15 kΩ
-45 %	12.2 kΩ
-50 %	10 kΩ

Table 5–1 — Values for trim down by percentage (Refer to [product data sheet](#) for allowable trim ranges at [vicorpower.com](#))

TRIMMING ON THE WEB ([VICORPOWER.COM](#))

Trim values are calculated automatically. Design Calculators are available on Vicor’s website in the PowerBench™ section at [vicorpower.com/tools](#).

Resistor values can be easily determined for fixed trim up, fixed trim down and for variable trimming applications.

In addition to [trimming information](#), the website also includes design tips, applications circuits, EMC suggestions, thermal design guidelines and [PDF data sheets](#) for all available Vicor products.

Fixed Trim Down		
Vnom	V (Desired)	Trim Resistor [a]
5 V	4.5 V	90.9 kΩ
	3.3 V	19.6 kΩ
	2.5 V	10.0 kΩ
15 V	13.8 V	115 kΩ
24 V	20 V	49.9 kΩ
48 V	40 V	49.9 kΩ
	36 V	30.1 kΩ

Table 5–2a — Values for fixed trim down by voltage

Fixed Trim Up		
Vnom	V (Desired)	Trim Resistor [a]
5 V	5.2 V	261 kΩ
	5.5 V	110 kΩ
12 V	12.5 V	953 kΩ
	13.2 V	422 kΩ
15 V	15.5 V	1.62 MΩ
	16.5 V	562 kΩ
24 V	25 V	2.24 MΩ
48 V	50 V	4.74 MΩ

Table 5–2b — Values for fixed trim up by voltage

[a] Values listed in the tables are the closest standard 1% resistor values.

Resistor Values for Fixed Output Voltage Trimming back to main window

Vicor product: VI-200 VI-J00 Maxi, Mini, and Micro

Notes: VI-200 and VI-J00 — Minimum preload of 1% should be maintained
Maxi, Mini, and Micro — Consult factory when trimming below –10%

Nominal output voltage: 5V

Trim range: 2.5 to 5.5 V or Vnom -50 to +10 %

Desired output voltage: 5.5 V or Vnom +10 %

Clear Output Voltage

Calculate Trim resistor value: 110 K ohm Reset

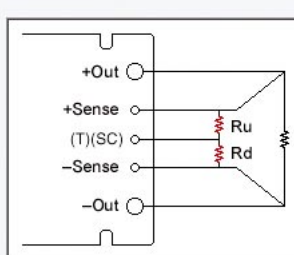

Ru = Trim up resistor
110 K ohm

Rd = Trim down resistor
K ohm