

Logic Disable. (Figure 7–1) The GATE IN pin of the module may be used to turn the module on or off. When GATE IN is pulled low (<0.65 V @ 6 mA, referenced to –Vin), the module is turned off. When GATE IN is floating (open collector), the module is turned on. The open circuit voltage of the GATE IN pin is less than 10 V. This applies to VI-/MI-200, VI-/MI-J00 and MegaMod / MI-MegaMod Family modules.

Output Voltage Programming. (Figure 7–2) Consult Vicor’s Applications Engineering Department before attempting large signal applications at high repetition rates due to ripple current considerations with the internal output capacitors. This applies to VI-/MI-200, VI-/MI-J00, CompPAC/MI-CompPAC, FlatPAC and MegaMod / MI-MegaMod Family modules.

$$V_{out} = \frac{V_{trim} \times V_{nom}}{2.5}$$

Negative Inputs (with positive ground). (Figure 7–3) Vicor modules have isolated inputs and outputs making negative input configurations easy. Fusing should always be placed in the positive lead.

Remote Sensing. (Figure 7–4) Output voltage between +OUT and –OUT must be maintained below 110% of nominal. Do not exceed 0.25 V drop in negative return as the current limit setpoint is moved out proportionately. The sense should be closed at the module if remote sensing is not desired. Applies to VI-/MI-200, VI-/MI-J00, CompPAC/MI-CompPAC, FlatPAC and MegaMod / MI-MegaMod Family modules. Excessively long sense leads and / or excessive external capacitance at the load may result in module instability. Please consult Vicor Applications Engineering for compensation methods.

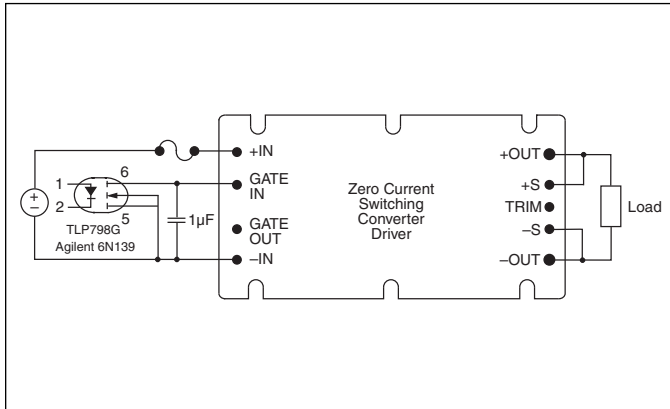

Figure 7–1 — Logic disable

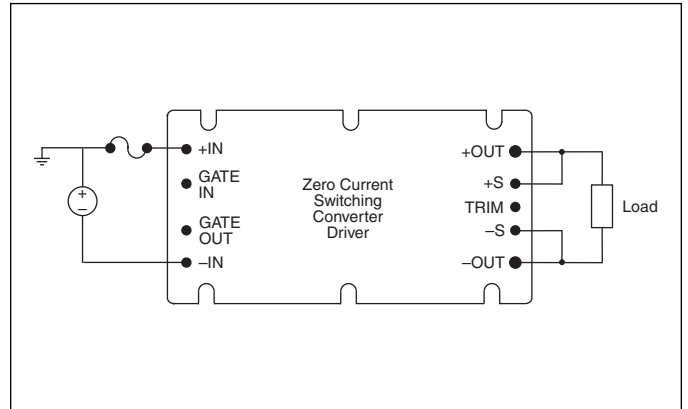

Figure 7–3 — Negative inputs (with positive ground)

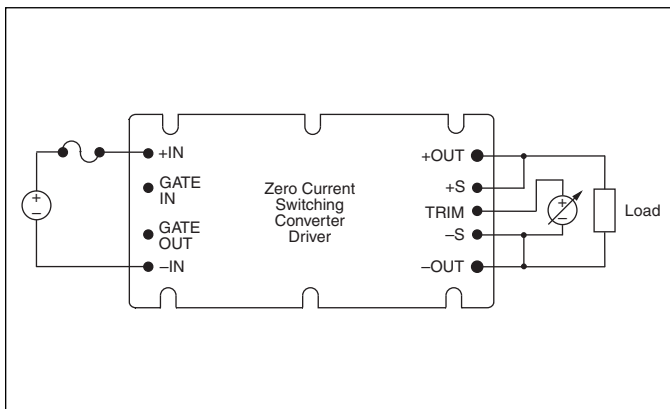

Figure 7–2 — Output voltage programming

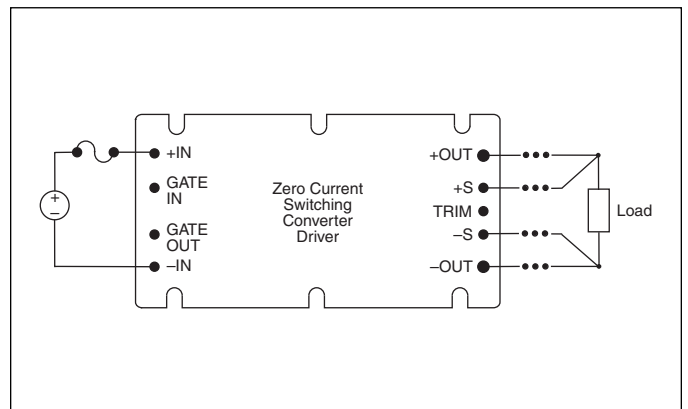

Figure 7–4 — Remote sensing

Parallel Boost. (Figure 7-5) U.S. Patent #4,648,020 — other patents pending. To retain accurate power sharing between a Driver and (n) number of Boosters, provide adequate input and output power bussing. This applies to VI-/MI-200 and MegaMod / MI-MegaMod Family modules. See [Module Do's and Don'ts](#) for recommended external components. (Section 3)

Programmable Current Source. (Figure 7-6) Module output voltage should not exceed the rated voltage of the operational amplifier. This applies to VI-/MI-200, VI-/MI-J00, ComPAC / MI-ComPAC, FlatPAC and MegaMod / MI-MegaMod Family modules.

NOTE: When using a VI-J00 module, the TRIM pin voltage should be clamped to 2.75 V to avoid damage to the module. This corresponds to the maximum trim up voltage. This circuit or functional equivalent must be used when charging batteries. Do not exceed the nominal current ratings of the converter. Example,

$$\frac{P_{out}}{V_{nominal}}$$

Dual Output Voltages. (Figure 7-7) Vicor modules have isolated outputs so they can easily be referenced to a common node creating positive and / or negative rails.

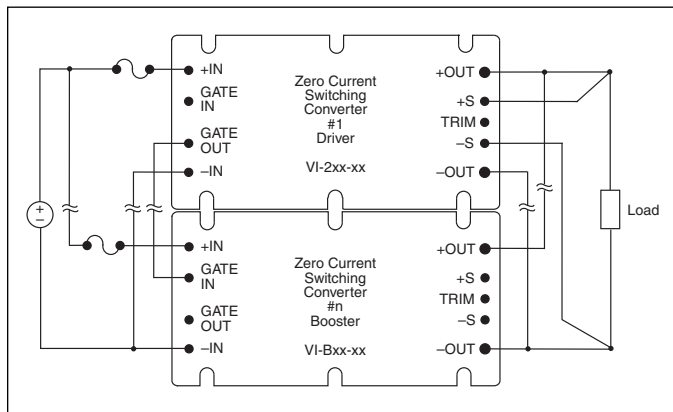

Figure 7-5 — Parallel boost. U.S. Patent #4,648,020 — other patents pending.

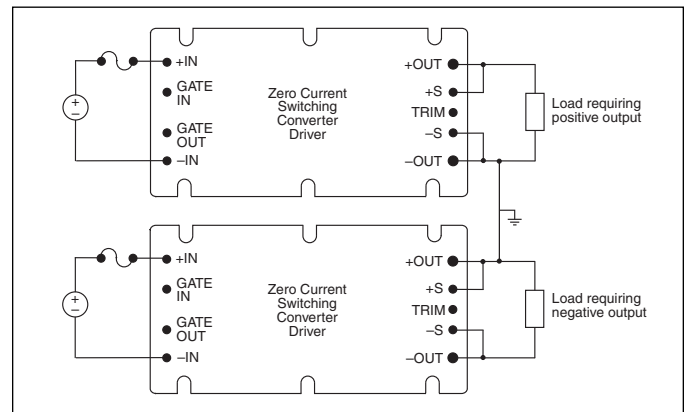

Figure 7-7 — Dual output voltages

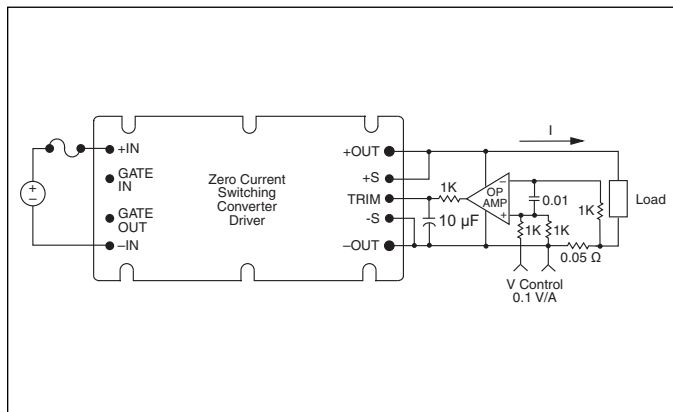

Figure 7-6 — Programmable current source