



Data Sheet

MI-IAM™

Input Attenuator Modules



Features

- Inputs: 28 Vdc and 270 Vdc
- MIL-STD-461C/D/E EMI compliance
- MIL-STD-810 environments
- MIL-STD-704A-F, MIL-STD-1275A/B/D and DO-160E transients and spikes
- Reverse polarity protection
- Output power: Up to 200 W from any combination of MI-200 or MI-J00 modules
- Expansion port for additional power
- Short circuit protected
- Size: 2.28" x 2.4" x 0.5" (57,9 x 61,0 x 12,7 mm)

Product Highlights

The MI-IAM is an accessory product to Vicor's MI-Series of DC-DC converters that provides EMI filtering and transient protection. Designed for use with all 28 V and 270 V input MI-200 or MI-J00 converters, the MI-IAM can drive any number of modules with output loads to 200 W.

The MI-IAM meets the conducted emissions specifications of MIL-STD-461C/D/E and offers complete input transient, surge, and spike protection to the most severe levels of MIL-STD-1275, MIL-STD-704 and DO-160. Reverse polarity protection and overvoltage lockout provide additional safeguards against potentially damaging line conditions. High power arrays can be configured using the expansion port capability of the MI-IAM.

Compatible Products

- MI-200, MI-J00 (Inputs: 2 and 6)
- Mega Modules (Inputs: 2 and 6)

Packaging Options

Standard: Slotted baseplate

SlimMod: Flangeless baseplate, option suffix: - S
Example: MI - AXX - XX - S

FinMod: Finned heat sink, option suffix:
- F1, - F2, -F3 or -F4

Examples:

- MI - AXX - XX -F1, 0.25" fins, longitudinal
- MI - AXX - XX -F2, 0.50" fins, longitudinal
- MI - AXX - XX -F3, 0.25" fins, transverse
- MI - AXX - XX -F4, 0.50" fins, transverse

MI-IAM Specifications

(Typical at TBP = 25°C, nominal line, 75% load, unless otherwise specified)

Input Characteristics

Parameter	Min	Typ	Max	Units	Notes
28 Vdc modules					
Steady state input	16	28	50	Vdc	
Input spike limit	-600		600	Vdc	10 μs, 50 Ω per MIL-STD-704A
	-250		250	Vdc	70 μs, 15 mJ per MIL-STD-1275A/B/D
Input surge limit			100	Vdc	50 ms, 0.5 Ω per MIL-STD-1275A/B/D
			80	Vdc	100 ms per DO-160E, Sec. 16, Cat. Z
Overvoltage shut down ^[a]	50			Vdc	100 ms, automatic recovery
Reverse polarity protection					Shunt diode: input fuse required
Recommended fuse			20	Amps	F03A type
270 Vdc modules					
Steady state input	125	270	400	Vdc	
Input spike limit			800	Vdc	10 μs, 50 Ω
	-600		600	Vdc	100 μs, 15 mJ
Input surge limit			500	Vdc	100 ms, 0.5 Ω
Overvoltage shut down ^[a]	400			Vdc	100 ms, automatic recovery
Reverse polarity protection					Shunt diode: input fuse required
Recommended fuse			4	Amps	F03A type
All models					
No load power dissipation		0.5	1.5	Watts	
Inrush current		110	125	% I _{IN}	Steady state, I _{IN} 10 ms

^[a] The MI-IAM disables downstream converters and clamps the converter input voltage at a safe level.

Output Characteristics

Parameter	Min	Typ	Max	Units	Test Conditions
Clamp voltage					
28 Vdc input			60	Vdc	
270 Vdc input			420	Vdc	
Output power			250	Watts	
Internal voltage drop					
28 Vdc		0.6		Vdc	
270 Vdc		0.85		Vdc	
Overload protection					
28 Vdc input			20	Amps	Foldback threshold; auto recovery
270 Vdc input			4	Amps	with latched shut down after 10 ms

Isolation Characteristics

Parameter	Min	Typ	Max	Units	Notes
Input to base		1,500		Vrms	1 minute
Output to base		1,500		Vrms	1 minute

EMI Characteristics MIL-STD-461

Parameter	Notes
Input power leads	
Conducted emissions	CE01, CE03, CE07 CE101, CE102 MIL-STD-461C MIL-STD-461D/E
Conducted susceptibility	CS01, CS02, CS06, CS101, CS114, CS115, CS116 MIL-STD-461C MIL-STD-461D/E

Model Selection Chart

Model Number	Nominal Input Voltage	Input Range	Compatible MI-Series	Converter
MI-A22-MU	28 Vdc	16 – 50 Vdc	MI-22x-Mx and MI-J2x-Mx	M-grade
MI-A66-MU	270 Vdc	125 – 400 Vdc	MI-26x-Mx and MI-J6x-Mx	M-grade
MI-A22-IU	28 Vdc	16 – 50 Vdc	MI-22x-Ix and MI-J2x-Ix	I-grade
MI-A66-IU	270 Vdc	125 – 400 Vdc	MI-26x-Ix and MI-J6x-Ix	I-grade

SPECIFICATIONS

(typical at $T_{BP} = 25^{\circ}\text{C}$, nominal line and 75% load, unless otherwise specified)

■ ENVIRONMENTAL – MIL-STD-810D

Parameter	Min	Typ	Max	Units	Test Conditions
Altitude - method 500.2	70,000			feet	Procedure II
Humidity - method 507.2	88/240			%/hours	Procedure I, cycle 1
Acceleration - method 513.3	9			g	Procedure II
Vibration - method 514.3	20			g	Procedure I, category 6
Shock - method 516.3	40			g	Procedure I

■ RELIABILITY – MIL-HDBK-217F (MI-A22-MU)

Parameter	Min	Typ	Max	Units	Test Conditions
25°C Ground Benign: G.B.		5,637		1,000 hours	
50°C Naval Sheltered: N.S.		1,014		1,000 hours	
65°C Airborne Inhabited Cargo: A.I.C.		795		1,000 hours	

■ THERMAL CHARACTERISTICS

Parameter	Min	Typ	Max	Units	Test Conditions
Efficiency		97		%	
Baseplate to sink		0.14		$^{\circ}\text{C}/\text{Watt}$	
Operating temperature, baseplate			100	$^{\circ}\text{C}$	See product grade specifications
Storage temperature			125	$^{\circ}\text{C}$	See product grade specifications

■ MECHANICAL SPECIFICATIONS

Parameter	Min	Typ	Max	Units	Test Conditions
Weight		3.0 (85)		ounces (grams)	

■ PRODUCT GRADE SPECIFICATIONS

Parameter	I-Grade	M-Grade
Storage temperature	-55°C to +125°C	-65°C to +125°C
Operating temperature (baseplate)	-40°C to +100°C	-55°C to +100°C
Power cycling burn-in	12 hours, 29 cycles	96 hours, 213 cycles
Temperature cycled with power off 17°C per minute rate of change	12 cycles -65°C to +100°C	12 cycles -65°C to +100°C
Test data supplied at these temperatures ^[a]	-40°C, +80°C	-55°C, +80°C
Warranty	2 years	2 years
Environmental compliance	MIL-STD-810	MIL-STD-810
Derating	NAVMAT P-4855-1A	NAVMAT P-4855-1A

^[a] Test data available for review or download from vicorpower.com

SPECIFICATIONS (CONT.)

ENVIRONMENTAL QUALIFICATIONS

Parameter	Qualification
Altitude	MIL-STD-810D, Method 500.2, Procedure III, explosive decompression (40 K ft.).
	MIL-STD-810D, Method 500.2, Procedure II, 40,000 ft., 1000 – 1500 ft./min. to 70,000 ft., unit functioning
Explosive Atmosphere	MIL-STD-810C, Method 511.1, Procedure I
Vibration	MIL-STD-810D, Method 514.3, Procedure I, category 6, helicopter, 20 g
	MIL-STD-810D, Method 514.3 random: 10 – 300 Hz @ 0.02 g ² /Hz, 2000 Hz @ 0.002 g ² /Hz, 3.9 total G rms 3 hrs/axis. Sine: 30 Hz @ 20 g, 60 Hz @ 10 g, 90 Hz @ 6.6 g, 120 Hz @ 5.0 g, 16.0 total G rms, 3 axes
	MIL-STD-810E, Method 514.4, Table 514.4-VII, ±6 db/octave, 7.7 G rms, 1hr/axis
Shock	MIL-STD-810D, Method 516.3, Procedure I, functional shock, 40 g
	MIL-STD-202F, Method 213B, 18 pulses, 60 g, 9 msec
	MIL-STD-202F, Method 213B, 75 g, 11 ms saw tooth shock
	MIL-STD-202F, Method 207A, 3 impacts / axis, 1, 3, 5 feet
Acceleration	MIL-STD-810D, Method 513.3, Procedure II Operational test, 9 g for 1 minute along 3 mutually perpendicular axes
Humidity	MIL-STD-810D, Method 507.2, Procedure I, cycle I, 240 hrs, 88% relative humidity
Solder Test	MIL-STD-202, Method 208, 8 hr. aging
Fungus	MIL-STD-810C, Method 508.1
Salt-Fog	MIL-STD-810C, Method 509.1

SAFE OPERATING AREA ^[a]

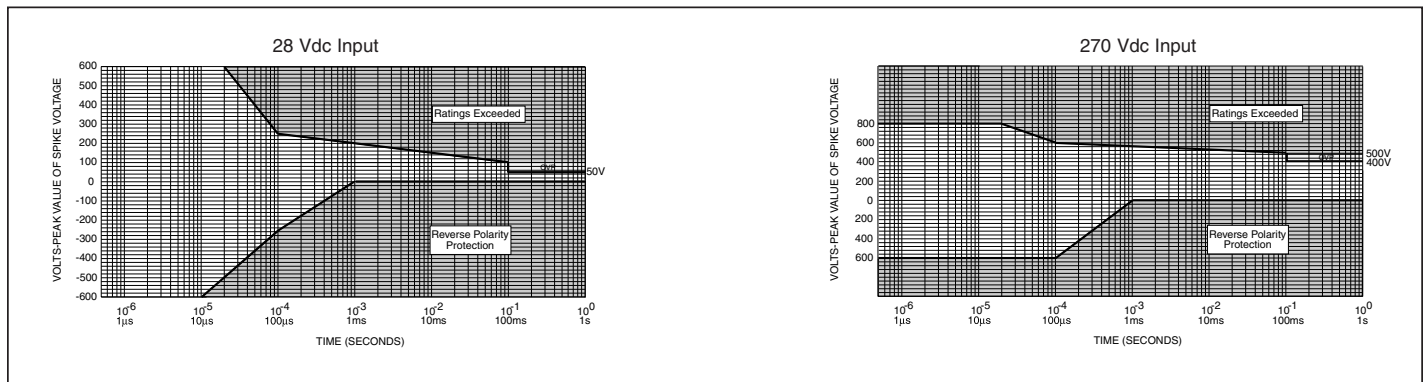

^[a] Refer to Input Characteristics

TYPICAL CONNECTION DIAGRAM

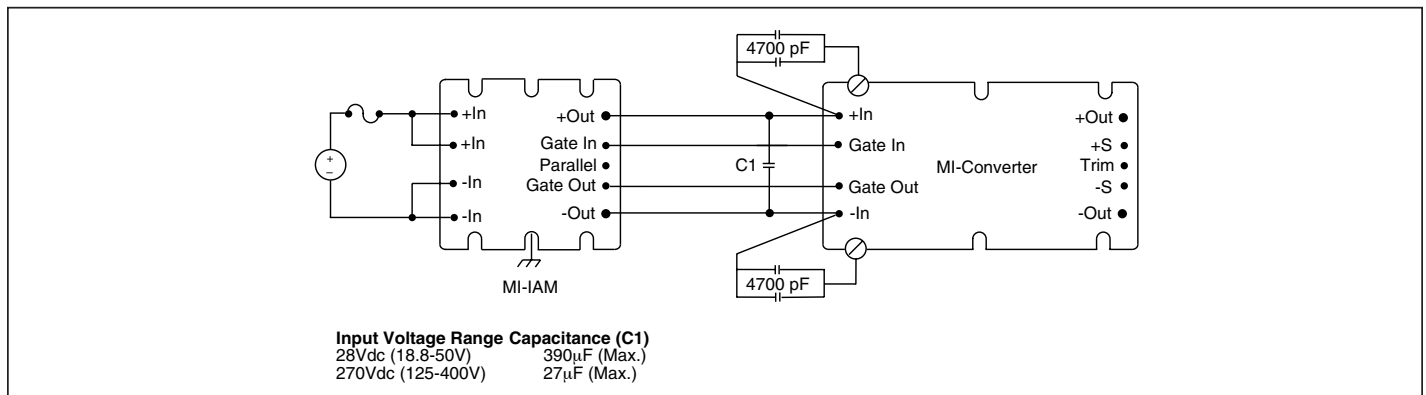

MECHANICAL DRAWING

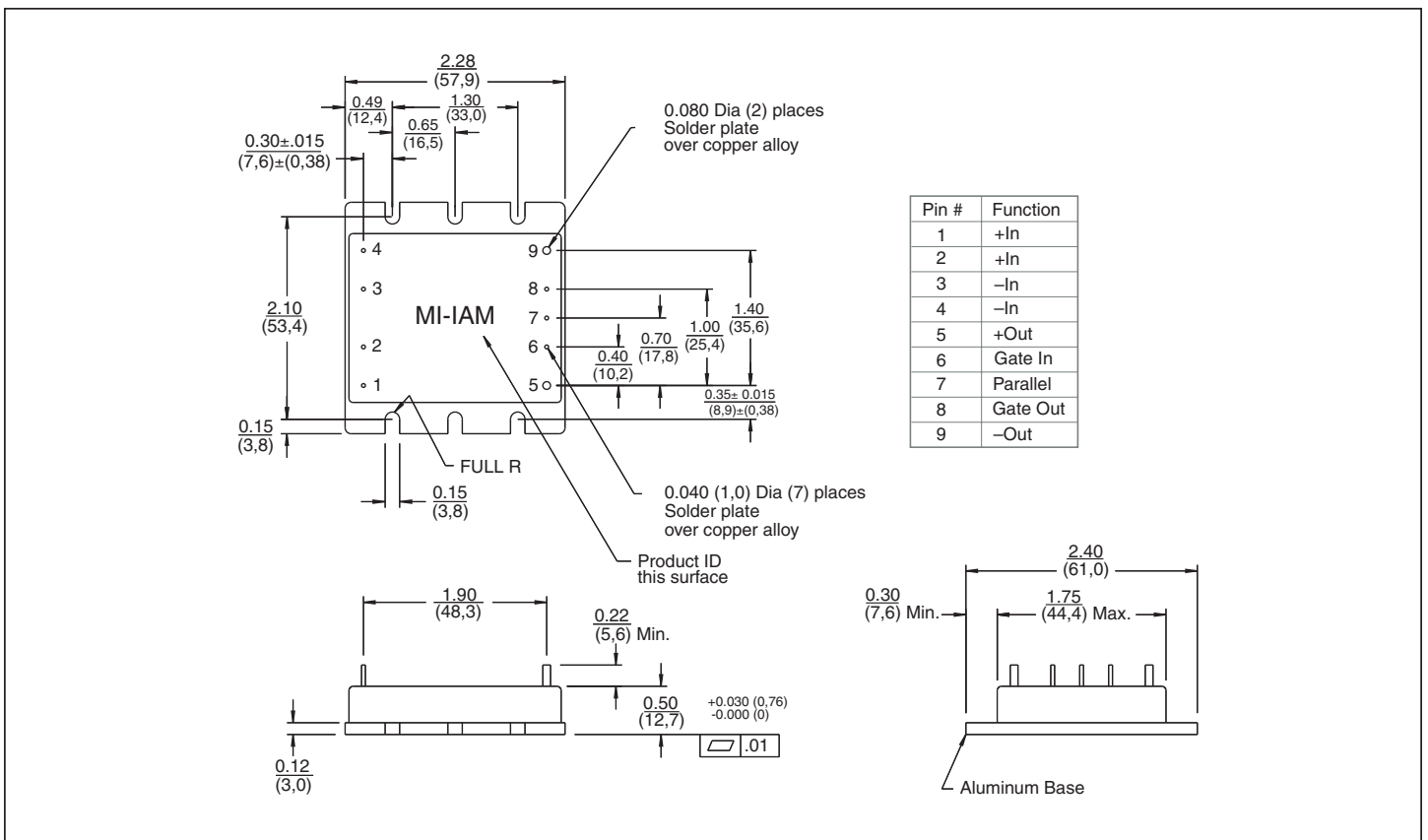

Note: For alternate packaging options refer to the mechanical drawing page of vicorpower.com

Warranty

Vicor products are guaranteed for two years from date of shipment against defects in material or workmanship when in normal use and service. This warranty does not extend to products subjected to misuse, accident, or improper application or maintenance. Vicor shall not be liable for collateral or consequential damage. This warranty is extended to the original purchaser only.

EXCEPT FOR THE FOREGOING EXPRESS WARRANTY, VICOR MAKES NO WARRANTY, EXPRESS OR IMPLIED, INCLUDING, BUT NOT LIMITED TO, THE WARRANTY OF MERCHANTABILITY OR FITNESS FOR A PARTICULAR PURPOSE.

Vicor will repair or replace defective products in accordance with its own best judgement. For service under this warranty, the buyer must contact Vicor to obtain a Return Material Authorization (RMA) number and shipping instructions. Products returned without prior authorization will be returned to the buyer. The buyer will pay all charges incurred in returning the product to the factory. Vicor will pay all reshipment charges if the product was defective within the terms of this warranty.

Information published by Vicor has been carefully checked and is believed to be accurate; however, no responsibility is assumed for inaccuracies. Vicor reserves the right to make changes to any products without further notice to improve reliability, function, or design. Vicor does not assume any liability arising out of the application or use of any product or circuit; neither does it convey any license under its patent rights nor the rights of others. Vicor general policy does not recommend the use of its components in life support applications wherein a failure or malfunction may directly threaten life or injury. Per Vicor Terms and Conditions of Sale, the user of Vicor components in life support applications assumes all risks of such use and indemnifies Vicor against all damages.

Vicor's comprehensive line of power solutions includes high density AC-DC and DC-DC modules and accessory components, fully configurable AC-DC and DC-DC power supplies, and complete custom power systems.

Information furnished by Vicor is believed to be accurate and reliable. However, no responsibility is assumed by Vicor for its use. Vicor components are not designed to be used in applications, such as life support systems, wherein a failure or malfunction could result in injury or death. All sales are subject to Vicor's Terms and Conditions of Sale, which are available upon request.

Specifications are subject to change without notice.

Intellectual Property Notice

Vicor and its subsidiaries own Intellectual Property (including issued U.S. and Foreign Patents and pending patent applications) relating to the products described in this data sheet. Interested parties should contact Vicor's Intellectual Property Department.

Vicor Corporation
25 Frontage Road
Andover, MA, USA 01810
Tel: 800-735-6200
Fax: 978-475-6715

email

Customer Service: custserv@vicorpower.com
Technical Support: apps@vicorpower.com